



Des Moines WoodTurners Chapter Meeting Announcement & Newsletter

November 2024 a 501(c)(3) Non-profit Organization Bulletin 2024-11

Calendar Update - Wednesday Networking Meetings

The November networking will be on **November 20th**, not November 27th which is the day before Thanksgiving.

The December networking will be on **December 18th**, not December 25th which is, well, you know!

November 9th Presentation Rob Wallace

Focus on Form - Improving your Turnings through Self-Critique



There are an infinite number of shapes a woodturner can create on the lathe to make bowls, vessels, hollow forms, platters, spindles, etc. - whatever shape the turning becomes, one of the major goals should be that it is visually and aesthetically appealing. At the end of the turning process, the visual appeal of what has been created really comes down to two major aspects of how the piece is perceived: form and finish. This demonstration will focus specifically on aspects of "form" and will be presented in three phases: The first will be a brief review of the importance of "pleasing" general shapes, proportions, and properly executed curves, including several recommendations and guidelines to help woodturners achieve some of these aesthetic goals. The second phase will be to view several pre-turned pieces, critique them for their good and bad visual aspects, and identify "problems" of the forms shown. The third and final phase will be to "fix" the problems identified from the group's critique by re-shaping them on the lathe, and thus demonstrate how a few simple changes in shape, proportion, or curve can

drastically improve the aesthetic qualities of the turned forms. This demonstration is intended to be helpful to all woodturners, regardless of experience level.

Rob Wallace has been involved in a range of woodturning activities for over 30 years and enjoys the challenge of showcasing the beauty and figure of wood in the various pieces he creates at the lathe. His interests have been focused on this aspect of woodworking as a creative expression of the use of wood as an artistic medium, and enjoys teaching about woodturning, concentrating his efforts on providing instruction on tools, equipment, and techniques. He has been a frequent demonstrator at local, regional, and national woodturning symposia, including the recent 2024 AAW National Symposium in Portland, and also provides remote demonstrations to woodturning groups around the country.

(Continued on next page)

Rob Wallace, continued

Rob has participated in a wide range of juried art exhibitions throughout Iowa and sells his turned artwork by consignment or commission at several different galleries. Rob served one 3-year term on the Board of Directors of the American Association of Woodturners, is the President of the Ames Area Woodturners chapter of the AAW, and has been an active member of the Board of Trustees of the Octagon Center for the Arts in Ames, serving as its President for several years. In addition to woodturning, he has interests in gardening, fishing, amateur radio, and brewing beer.

Rob's Website: [Rob Wallace - Woodturner](#)



November Meeting Turning Challenge

You are challenged to turn a 2x2x4 inch stock into a profitable product. Your entry (or entries) will be judged on ease of turning and salability. There is no limit on enhancements, however added costs affect total score.

In addition to a prize the winner will have the opportunity to sell replicas of the project at the State Fair (Fair admission and parking will be provided).

Questions? Email Mike Hamilton at kmhamilton9@msn.com.

Free Wood at the November 9th Meeting

A special thanks to **LeRoy Monson** for donating wood for club members to turn. Thanks to Dennis Anderson, Kyle Knee, John Augsburger, and Jerry Peek for loading and sorting the wood and to Kyle for use of a truck and trailer. This wood will be available at the November 9 Chapter meeting in a trailer in the parking lot prior to club the meeting. We are asking for club members to help move any wood not taken from the trailer into the Mall backroom after the club meeting.



December 14th Chapter Meeting Special Event: Christmas Lunch at 11:00 AM Guest Speaker: Eric Hanson

The December 14 Chapter meeting will be a luncheon meeting for members and spouse/significant other at our Mall location. Doors will open at 11:00 AM with lunch at 11:30 PM.

Special guest **Eric Hanson** who anchors KCCI 8 News this Morning and tells the stories of Iowa characters in his "This is Iowa" segments will be our speaker following lunch.

We are asking members to bring several items you have turned to be on display that day.

We need a count for those attending the lunch. There will be a signup sheet at the November meeting or you can reply by email to Tom Whalley at themodelshop@mchsi.com providing your name and number attending. This is a special highlight of the year, so be sure to make plans to attend.

NOTE: The time is earlier than our normal club meetings. No lathe turning will be done at this meeting.

Election of officers will occur at the November 9th meeting.

Section 8.3.2 of our Chapter's by-laws states: "The names of nominees shall be announced to the membership either at the regular October monthly meeting and/or in the October Chapter Meeting Announcement prior to the regular November monthly meeting." Section 8.4 says: "The annual meeting and election will take place at the regular November monthly meetings of the Chapter with the term of office running from January 1 through December 31 of the following calendar year. Election will be by voice vote unless multiple persons are running for the same board position, which then requires a ballot vote. Proxy votes submitted by mail or email to a board member received prior to the day of the election will be allowed."

The nominees for the 2025 board's officers and directors are as follows:

President – Dennis Anderson

Vice President – Mark Hayes

Secretary – Will Zitterich

Treasurer – Stan Merrell

Director at Large –Mike Hamilton

Director of Membership – Dan Carlson

Director of Education – Tad Tadlock

Director of Programs – Tara Kinder

Pen Turning 101 - November 9th -11 am

Donna Byers and **Dan Carlson** will be at the mall on November 9th from 11am - noon discussing how to get started with pen-turning, geared towards those that have never turned a pen. This will be a discussion of tools and equipment needed to get started and other tools you may want after you get interested in turning more. They will provide examples and tips to help you get started. There will not be any turning during this presentation. This will be an opportunity for you to ask questions.

Future Educational Programs

January: **Glen Farmer** - Finishing the bottom of Bowls

February: **Dan Henderson** - Turning an Oval (Ed: is that even possible ??)

Des Moines Woodturners Baseball Hats

Baseball hats with "Des Moines Woodturners" on the front are available. The hats are \$15.00 each. Contact **Tom Whalley** if you would like to purchase. Email: Hats from Tom Whalley

Getting Coffee or Water? Maybe sign up to bring refreshments!

There is a refreshment sign-up sheet on the post near the coffee pot.

See Stan Merrell for reimbursement.

Festival of Lights

Once again the Woodcarvers, Woodturners, and Woodworkers clubs are collaborating to decorate a tree that will be selected by a sponsored donor at the Festival of Trees and Lights, in support of programs at Blank Children's Hospital that improve the health and lives of Iowa's children. This is the 41st year of the Festival, running from November 29 - December 1, 2024 with a total of \$14 million raised so far.

We're asking for handmade, wooden, finished Christmas tree decorations to decorate a seven-foot tree. A picture of last year's tree and decorating group is attached.

Completed ornaments can be turned in to **Greg Alberts** at the **November 9 Woodturners** monthly meeting.

We're also looking for someone to make or donate a tree skirt, as well as make or donate a tree topper, both of which will stay with the tree and go to the winning bidder.

We're also looking for help to decorate the tree on Sunday afternoon, November 24, starting at 1:00, at Veterans Memorial, downtown Des Moines.

Let me know if you can help with tree skirt, tree topper, or decorating the tree.

Thanks in advance, Greg Alberts, 515-314-7389



Reminder - Networking at the Chapter Meeting

If you would like to spend some time with your fellow turners, the Valley West location will be open before and after the Chapter meeting. The doors will open at 12 pm and close at about 4:30 pm.

Honey Dippers are big sellers at the State Fair

Parts to make Honey Dippers are available at the Valley West Mall.

Honey Dipper

Design: Dan England
Drawn by: Tom Whalley

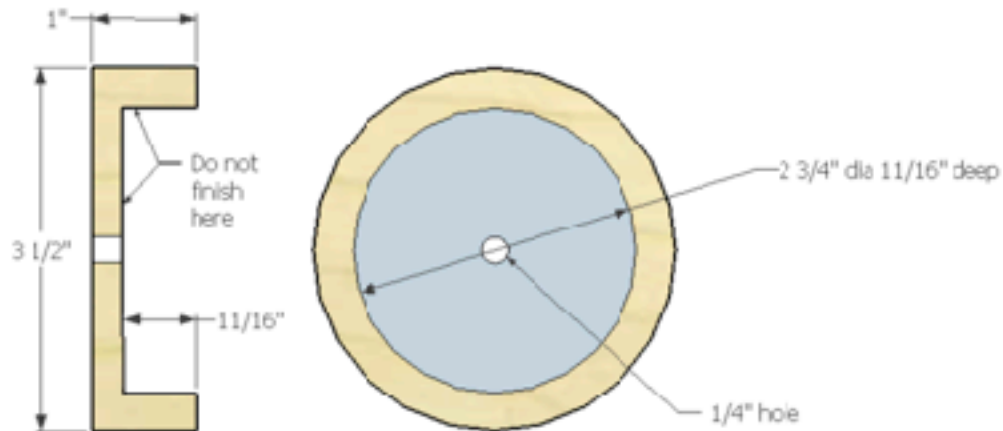

Lay out lids as shown and drill 2 3/4" dia 11/16" deep
Drill 1/4" center hole.
Rough out on the band saw.

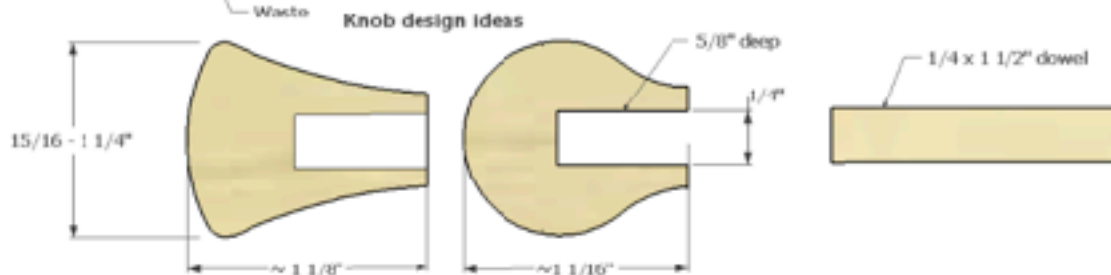
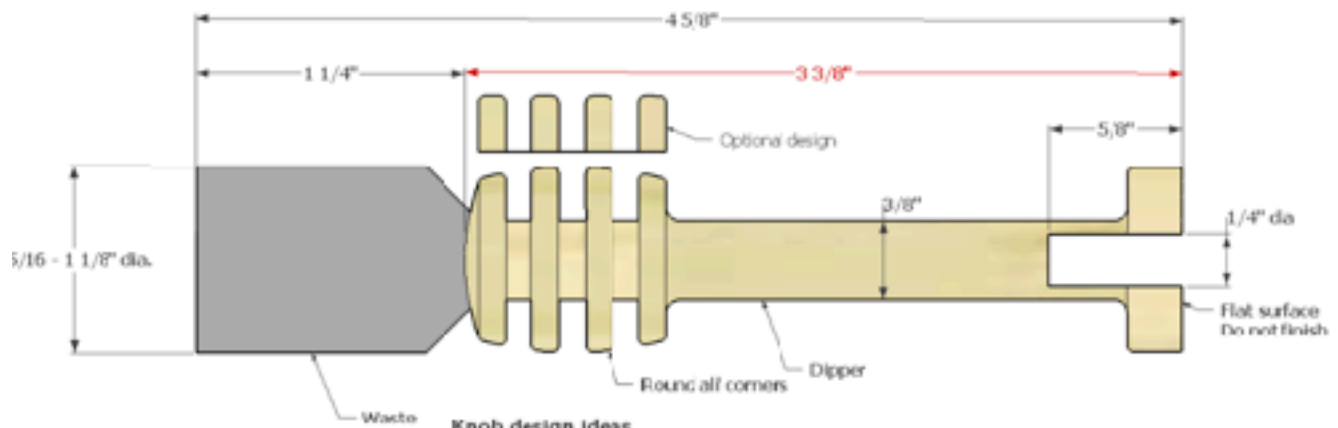

Honey Dipper Instructions

The Knob- Material:– 5/4 x 1-1/2" long – Hardwood. Do not use pine.

1. Mount the block on the lathe and drill a 1/4" hole 5/8" deep.
2. Turn the knob to any profile you choose. Remember, it is just a knob. Have fun with it They do NOT have to all be the same.
3. Part off and sand the top so that no parting marks are visible.

The Dipper - Material:– 5/4 hard maple or cherry

1. Turn the dipper as shown above.
2. **IMPORTANT** – the 3 3/8" dimension shown in red is also critical. If it is longer, the lid assembly will be too tall for the glass jar. Notice where the measurement starts and ends.
3. Sand smooth and finish with butcher block finish (but not the flat surface as shown above)
4. The 1 1/2" dowel may need to be sanded to fit into the dipper. It should not be a tight fit because it may split the dipper or the knob later. Glue the dowel into the end of the dipper. Remove glue squeeze out. Do not finish the surface of the dowel.
5. Finish only where shown with butcher block finish.

The Wood Lid – Material: 5/4 Hardwood - Same as knob. Do not use pine.

1. Drill 2 3/8" dia. x 11/16" deep recess.
2. Turn the lid to a 3 1/2" diameter.
3. Drill a 1/4" hole in the center of each lid.
4. Sand and finish the outside and bottom rim only. Do not finish the inside that was drilled out.
5. Using Gorilla 2-part epoxy, glue the jar ring to the lid and let dry. Do not over apply adhesive resulting in squeeze out around the outside of the jar ring. Do not get adhesive on the threaded rings inside the jar ring.
6. Glue the metal lid into the ring using Gorilla 2-part epoxy, clamp and let dry.
7. Carefully drill a 1/4" hole through the hole in the wood lid through the metal lid while holding a block under the lid assembly for support and to prevent the metal from bending.
8. Dry-fit the dipper through the hole in the lid and insert the knob. Make sure the knob fits tight against the lid. If the glue dowel is too long, trim it back before gluing the knob to it.
9. If all is well, glue the dipper to the lid using Gorilla 2-part epoxy and let it dry.
10. Glue the knob tightly to the lid using Titebond glue.
11. Finish the lid assembly
12. Buff the lid assembly.

Tom Whalley October 12th Demonstration Summary



Tom demonstrated techniques to minimize sanding and how to maximize the use of the wood block when making Christmas trees.

He began by mounting an oak spindle blank about 2x2x5 inches with the pith placed at each of the lathe centers. Many turners do not use oak on the lathe because it can be prone to chipping or tear out. He used a sharp spindle gouge to define the edges of the Christmas tree branches. He made cuts along the grain instead of against it to avoid any chip out and kept the gouge bevel tight against the wood to minimize the need for sanding. Tom demonstrated the use of a glue block to avoid wasting any of the wood when parting it off. He uses hot melt glue to hold on the glue block and denatured alcohol to remove it. Denatured alcohol will not damage the wood surface and affect the finishing.

Tom also demonstrated using a bottle stopper mounting bolt drilled into the Christmas tree blank will enable the turner to use all the wood blank and not have to cut any of it off. The Christmas tree can then be turned just as you would with turning a bottle stopper. The turner can also cut a tenon on one end of the blank and mount it in scroll chuck. Tom made a point that you can't turn a Christmas tree that does not need sanding without having sharp tools. He demonstrated using jigs to reliably set the angle of the grinding wheel to help the turner get a sharp edge on the gouge.

John Anderson October 12th Demonstration Summary



John demonstrated four enhancement tools to either cut or emboss the surface of wood to make designs that when a marker is used the design will stand out. These enhancements can be used on any part of the bowl like the rim or bowl foot. He began by using a chatter tool to cut a design on the end of a 3-inch diameter hard maple spindle blank. The chatter tool uses a metal blade that is mounted in a handle that when the blade is pressed to a turning spindle blank the blade vibrates and cuts a design into the wood. The chatter tool is only used on the end grain at about 1000 rpm. You get more chatter if the blade is longer and less texture if the blade is shorter. He also demonstrated the use of the Elf tool. The Elf uses a rotating carbide cutter centered in a bearing. Some of the cutters that he uses are a cove bit, point bit, ball cutter, and an oval cutter. A brush is used to burnish the wood surface. The cutter bit is pushed into the wood at the centerline at 400-500 rpm. The cutter is held at one location without moving it and just let the cutter make the design. It can be used on end grain and side grain. The next one he demonstrated was the Wagner tool. The Wagner tool uses a rotating wheel on a bearing shaft and is for embossing and not cutting. It works best at 400-500 rpm on a 2 inch diameter blank and slower for a larger blank. It has a coarse wheel and a fine wheel. It makes a spiral groove and can be used on side grain. He ended the demonstration using the Sorby Spiraling Tool. There are different sized wheel cutters with different sizes of teeth. It uses a platform that is mounted to the tool shaft to keep the tool from rotating when being used to cut a spiral design. The wheel cutters rotate on a shaft using bearings. The tool makes a spiral design as it is moved along the end of a spindle.

Will Zitterich, Secretary

October Show and Tell



Donna Byers



Donna Byers



Donna Byers



Dan England



Dan England



Albert Bustillos



Leroy Monson

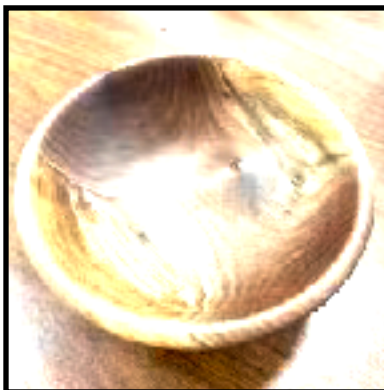

Dennis Anderson

Membership News from Dan Carlson

Time to Pay Your Dues

Our club currently has 187 members. Please welcome our newest member, **Jim Coddington** from Clive who joined in October.

I will start collecting dues from those of you that are not paid in advance. All members that have paid in advance would have received an email from me stating this. If you are one of those members that don't read your emails, paying again is not a problem for us.

I will be collecting dues (\$20) at the mall during November, December and our chapter meeting in January. After that dues increase to \$25. I will also be sending out in the near future a way for you to pay online. This was a very popular method last year and Stan Merrell is setting this option up for us again this year.

Remember, dues paid before the January chapter meeting remain the same \$20 we have charged for many years now. This low dues amount is because of your generosity in time to turn items we sell at the fair. At the mall you can pay me by cash, credit card or check.

Des Moines Woodturners Woodturning Scholarship

The Des Moines Woodturners offer a scholarship program for the benefit of chapter members. Woodturning can be an expensive endeavor. The cost of equipment such as a lathe, bandsaw, chainsaw, sharpening system, buffing system and the myriad of items like drive centers, scroll chucks, live centers, adapters, jaws, and faceplates can mount rapidly. In addition is the cost of turning tools, embellishing tools, specialty tools and a host of accessories, supplies and finishing products, not to mention the cost of wood if you don't have the capacity to harvest your own.

By the same token, three and five day woodturning educational events are also expensive when located out-of-state. Travel costs, lodging and tuition can easily run \$1,000 to \$1,700 per event.

This scholarship is not intended as a source of financial aid for those who might otherwise not be able to afford the educational experience. Instead, it is offered as an incentive to those serious about woodturning who are willing to expand their skills and knowledge and bring those skill-sets back to share with our members in a variety of ways. The scholarship can provide recipients a 25% to 50% discount toward the overall cost of their attendance expenses.

The purpose of the scholarship is to expand personal woodturning skills and knowledge and share their experience with fellow members by:

- Attending Chapter events and sharing their learning experience.
- Showing examples of their work as a result of their learning experience.
- Demonstrating what they learned at a chapter meeting, event, or class.
- Sharing their overall learning experience and confidence building experience.
- Encouraging members to expand their woodturning skills via similar educational experiences.
- Volunteering for Chapter leadership positions (wide variety of opportunities).

Mentoring Program

The Des Moines Woodturners Inc. (DMWT) invites members to use the Mentor Program. Below is a list of volunteers, members in good standing, who are willing to share their experience and answer specific questions to help you with a particular problem. Each mentor's strengths are noted along with their name and city location. Select who might be best to contact, based on your questions and how far they are from you. As volunteers, it will be up to the mentor to decide if they can help, whose shop will be used and what mentoring will look like based on the need.

Webpage: [DMWT Mentoring Program](#)

Dan Carlson, Clive
Phone 515-720-0637
Dano1466@yahoo.com

Dan will mentor in these areas:

1. Getting started with pen turning
2. Turning small ornaments
3. Turning small lidded boxes
4. Turning seam rippers,
pen letter openers
with or without a kit
5. Turning bottle stoppers

Glen Farmer, Ogden
Phone 517-395-0317
gfarmeriii@yahoo.com

Glen will mentor in these areas:

1. Bowl turning
2. Ornaments
3. Hollow forms
4. Coloring
5. Platters
6. Spindle work
7. Boxes
8. Harvesting wood/Blank cutting

LeRoy Monson, Waukee
Home Phone: 515-987-1655
Cell Phone: 515-745-9098
monsonlg@aol.com

LeRoy will mentor in these areas:

1. Spindle (including duplicating)
2. Bowls
3. Platters
4. Lidded box
5. One-way sharpening and set-up
6. Tool control
7. Bandsaw and lathe maintenance

Dave Rabe, Ottumwa
Phone: 641-680-1129
rjanetdave@gmail.com

Dave will mentor in these areas:

1. Basket illusion
2. Hollowing
3. Coloring/airbrush

Jack Rolison, Ottumwa
Phone: 641-683-5647
jd.rolison@outlook.com

Jack will mentor in these areas:

1. Bowl turning
2. Finishing
3. Coloring
4. Sharpening

Tad Tadlock, Winterset
Phone: 515-201-7403
tad4tahoe@aol.com

Tad will mentor in these areas:

1. Natural & naked edge bowls
2. Large & small bowls
3. Platters
4. Boxes
5. Open void vessels
6. Sharpening

Jack Kennedy, Winterset
Phone: 515-462-3141j
jkennedywinterset@att.net

Jack will mentor in these areas:

1. Closed Segment Bowls
2. Open Segment Bowls

Training Class Graduates

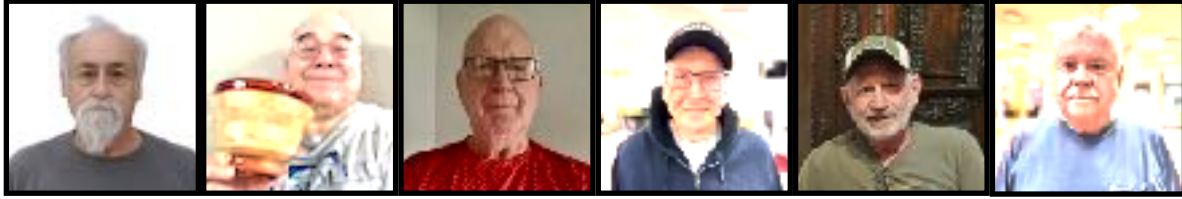

Segmenting

Mike Mauro, Vern Kindernecht, Tom Smith,
Jack Kennedy (instructor), Stan Merrell (instructor), Dan England (instructor)



Bowl

Tad Tadlock (instructor), John Amberg (instructor), Duane Groenenboom (instructor),
Theo Filanowicz, Mark Hayes (instructor), Jerry Reiman, Tim Heady



Skew

Theo Filanowicz, John Amberg, Ted Redenius, Tom Baker (instructor)

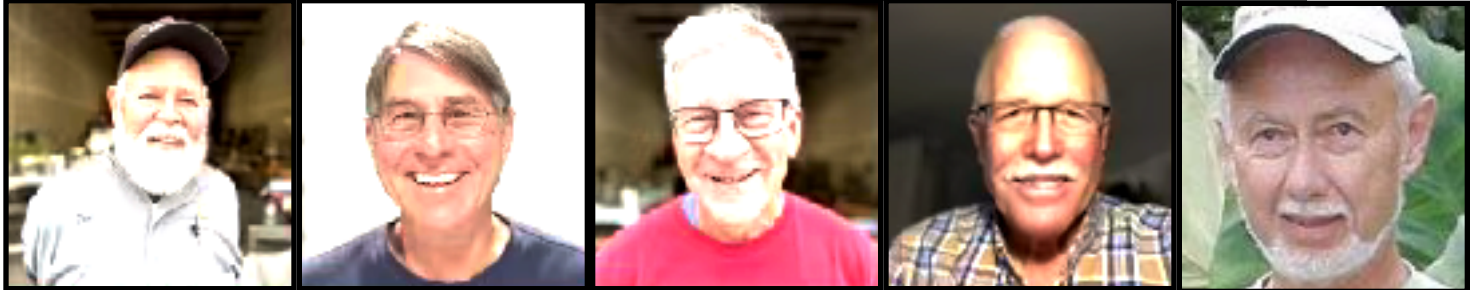
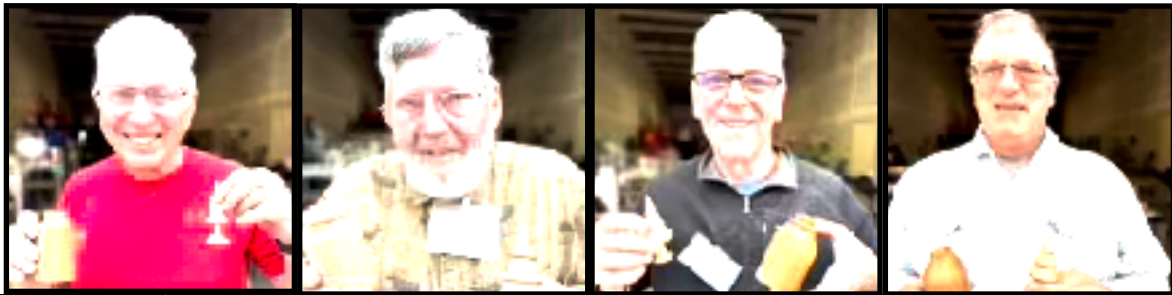

Basic Woodturning
 Students: Jim Coddington, Darrell Brown, Tom Golding, Duane Strempe
 Instructors: Tad Tadlock, Duane Groenenboom, Mark Hayes, John Amberg, Dick Meuler

2024 Fall Class Enrollment
 If you are enrolled in a class you did not want or not enrolled in a class you thought you were enrolled in, please contact John Amberg ASAP. (johnaamberg@yahoo.com)

Basic Sharpening	Nov. 4	Tim Heady	Kim Eaton	Scott Core	Theo Filanowicz
Basic Bowl	Nov. 11	Todd Troll	Tim Heady	Tom Golding	Duane Strempe
Basic Woodturning	Nov. 18 & 25	Vern Kindernecht	Jeff Newhook	Brad Huyser	Paul Fitzpatrick

Educational Opportunities

American Association of Woodturners 39th International Symposium June 12-15, 2025, St. Paul, MN.

Registration opens November 18, 2024

Link: [AAW Symposium](#)

Information about Stuart Batty Woodturning Classes

Instructors & Woodturning School: All our instructors have substantial teaching experience. They have all taught at numerous other schools or woodturning clubs worldwide, on various lathe sizes with mixed-level students and countless different setups. Our school is deeply committed to the art of woodturning. Each student will turn on a new 2hp or 3hp Powermatic lathe. Lathes will be set to a comfortable ergonomic height based on the student's height. We provide the wood, tools, and chucks needed for each class; however, students are welcome to bring their tools.

Video Recorded Class Demonstrations: We are happy to announce that all our instructors have agreed to have their class demonstrations video recorded. This footage will be professionally edited after the class and made available for private online viewing by the students who have attended this class. Viewing will be time-restricted to 9 months after the class. All copyright to the footage from each class belongs to the individual instructors. This is unique in woodturning and will enable students to watch the instructor's various demonstrations without taking notes. It also allows students to refresh themselves on what they learned and practiced long after class. Note that many woodturning schools do not allow any video recording.

Start & Finish Times: All classes start at 8:00 a.m. and finish at 4:30 p.m. Instructors can run the class past 4:30 p.m. if necessary and believe it is safe to do so, as students are tired by the end of the day.

Lunch Provided: We will provide lunch for students in our kitchenette area each day at noon; this is included in the class cost.

Maximum Number of Students: Ten. We limit the number of students for each class to ten. Along with the instructor, all classes will have a minimum of one very experienced assistant.

Travel & Local Accommodation: Our facility is 4 miles from downtown Boulder, Colorado, and 30 miles from Denver International Airport. A bus runs every hour between the two. We are discussing discounted rates for our class students with a local hotel. We will arrange pick-up and drop-off for each day of class from this hotel.

Payment: 50% deposit, balance due two weeks before class start date. If a student needs to cancel, we will refund the deposit up to four weeks before class starts.

If a student cancels less than four weeks before the class, the deposit will be credited to a future class of their choice or refunded if we can fill the vacant space or have a waiting list for that class. There is a \$50 cancellation fee.

Accommodation: You're welcome to choose any accommodation you prefer; however, we've partnered with Homewood Suites by Hilton to offer you 15% of any booking (just click the underlined name) Each room includes a mini kitchenette, and it's within walking distance of a supermarket. There's also a minibus available to take you anywhere within a 5-mile radius of the hotel, allowing you to explore Boulder.

Click for Full Description of Each Class: [Stuart Batty Woodturning School](#)

Board Members and Officers

Please contact any member of the board with your comments, suggestions, or concerns.

President: Tom Whalley (515) 321-6323 themodelshop@mchsi.com	Treasurer: Stan Merrell (515) 491-5411 srmerrell1@gmail.com	Programs: Volunteer Needed
Vice President: Dennis Anderson (515) 975-8573 dennis.anderson.dca@gmail.com	Training: Tad Tadlock (515) 201-7403 tad4tahoe@aol.com	Safety: Mike Hamilton (515) 822-6771 kmhamilton9@msn.com
Secretary: Will Zitterich (515)-232-1765 wzitterich@mchsi.com	Membership: Dan Carlson (515) 720-0637 dano1466@yahoo.com	

Chapter Volunteers

AV Producer	Tom Baker
Camera	Tom Baker
Camera	Craig Wyckoff
Greeter	Vikki Morain
Greeter	Donna Byers
Librarian	Theo Filanowicz
Librarian	Rob Blink
Mentoring Program	Will Zitterich
Newsletter	John Amberg
Photographer	Gil Lea
Refreshments	Volunteers Needed
Scholarship Program	Mike Hamilton
State Fair Products	Duane Groenenboom
Training	Dick Meuler
Training	Tad Tadlock
Training	Duane Groenenboom
Training	John Amberg
Training	Stan Merrell
Training	Tom Baker
Training	Jack Kennedy
Training	Dan England
Training	Mark Hayes
Webmaster	Jim Bergeson

Event	Date	Refreshments
Chapter Meeting	Nov. 9, 2024, 1 PM	Gene Davis
* Networking Meeting	*Nov. 20, 2024, 9:30 AM	Kim Eaton
Chapter Meeting	Dec. 14, 2024, 1 PM	Christmas Lunch
* Networking Meeting	*Dec. 18, 2024, 9:30 AM	
Chapter Meeting	Jan. 11, 2025, 1 PM	
Networking Meeting	Jan. 22, 2025, 9:30 AM	
Tennessee Woodturners 36th Symposium	Jan. 31 -Feb. 1, 2025 Franklin, Tn.	
Chapter Meeting	Feb. 8, 2025, 1 PM	
Networking Meeting	Feb. 26, 2025, 9:30 AM	
Chapter Meeting	Mar. 8, 2025, 1 PM	
Networking Meeting	Mar. 26, 2025, 9:30 AM	
Chapter Meeting	Apr. 12, 2025, 1 PM	
Networking Meeting	Apr. 23, 2025, 9:30 AM	
Chapter Meeting	May 10, 2025, 1 PM	
Networking Meeting	May 28, 2025, 9:30 AM	
No Chapter Meeting June	No Chapter Meeting June	
AAW 39th Annual International Symposium	Jun. 12 thru 15, 2025 St. Paul, Mn.	
Networking Meeting	Jun. 25, 2025, 9:30 AM	
No Chapter Meeting July	No Chapter Meeting July	
Networking Meeting	July 23, 2025, 9:30 AM	
Iowa State Fair 2025	August 7 thru 17, 2025	
No Chapter Meeting August	No Chapter Meeting August	
Networking Meeting	August 27, 2025, 9:30 AM	
Chapter Meeting	Sep. 13, 2025, 1 PM	
Networking Meeting	Sep. 24, 2025, 9:30 AM	
Chapter Meeting	Oct. 11, 2025, 1 PM	
Networking Meeting	Oct. 22, 2025, 9:30 AM	
Chapter Meeting	Nov. 8, 2025, 1 PM	
*Networking Meeting	*Nov. 19, 2025, 9:30 AM	
Chapter Meeting	Dec. 13, 2025, 1 PM	
*Networking Meeting	*Dec. 17, 2025, 9:30 AM	
	* Rescheduled due to Holiday	

Woodturning FUNdamentals PDF - Great for Beginners

If you are a member of the AAW, you can access the Woodturning Fundamentals page at the AAW website.

The recent projects are: Wood Bottle Stopper, Shopmade Palm Saver for Comfortable Tools Make a Burnishing Tool, and Make a Seed Pot Press.

Here is the link: [Woodturning Fundamentals](#)

Newsletter Content

Please send in photographs of your work; we would love to see what you have made. If you have articles that you would like to have published or suggestions on how to improve the newsletter, please send them to johnaamberg@yahoo.com.

Links to the DMWT Website

[Meetings and Events](#)

[Woodturning Articles and Plans](#)

[Chapter Library List](#)

[Contact Board Members and Volunteers](#)

[Membership Application Form](#)

Additional Educational Opportunities

[AAW Articles and Videos](#)

AAW Articles, Videos, Safety and More (AAW membership required)

[Virtual Woodturning Demos](#)

Driven by master woodturner Trent Bosch. Most demos require a \$10 fee for a two-hour demo, but you can access the archived demo later if you wish. There are several turners providing demonstrations using this website.

[TurnAWoodBowl Videos](#)

Excellent series of free You Tube videos about turning Bowls. Kent Weakley also has a website: TurnAWoodBowl.com

Des Moines Woodturners Wearables

Members wanting Des Moines Woodturners logo embroidered on clothing are advised to purchase shirts, sweatshirts or turning smocks of their choice and style. These must be BRAND NEW and UNWASHED and can be delivered to any officer or board member. When enough items are collected to meet minimums, they will be taken to the embroiderer. Be sure to attach a note with your name to the collar of each garment submitted indicating if and how you want your name embroidered along with the Chapter logo. Costs to add the standard logo are \$10.00 per item. Personalized names can also be added for an additional \$6.00 per item. Chat with **Rob Beattie** if you have questions. 515-282-4532 or beattie.r@mchsi.com.

Membership Benefits - Supplier Discounts

One of the benefits of DMWT club membership are discounts with participating suppliers. We strongly encourage you to use local suppliers whenever possible. Before they ring you up, show discount suppliers your Des Moines Woodturners membership card. BUY LOCAL when you can, Mail Order when you have no other choice!!

Woodsmith Store	A 10% discount is available on most items without a cord. 2900 Clocktower Square, Suite #230, West Des Moines. https://thewoodsmithstore.com/ Mon thru Fri 9 to 6, Sat 9 to 5, Sun 12 to 4. Phone: (515) 254-9494
True Value Hardware	63rd and Grand in WDM offers a 10% discount on most non-sale items. If you're in doubt, ask a sales associate. They are known for having nearly anything you'd ever want especially hardware and fasteners. Mon thru Fri 7 to 8, Sat 7 to 6, and Sun 9 to 5. Phone: 515 279-9905
Acme Tools	629 SW 9th St. in Des Moines offers a 10% discount to members except for sale items and power tools or things with a cord. If you're in doubt, ask a sales associate. Mon thru Fri 7 to 5:30, Sat 8-5:30. Phone: 515 244-4189
Renewal by Andersen	517 Railroad Ave. in WDM (Valley Junction) offers 5% discount on top of any other promotion(s) for home/business replacement windows and doors. Mon thru Fri 8-5. Phone: 515 274-9700
Woodcraft	8645 Bluejacket Road, Lenexa, KS 66214, Phone: (913) 599-2800, Email: kansas-retail@woodcraft.com . Website link . 10% discount supplier for woodturning tools, supplies, and accessories not <u>sold</u> locally. Show your DMWT membership card in store for discount on most items except tools with a cord or battery and other selected premium and sale items. Only valid for in-store purchases.

American Association of Woodturners (AAW)

We recommend an AAW membership because it offers you many additional woodturning resources:

- ** Six issues of American Woodturner magazine each year.
- ** Four issues of Woodturning FUNdamentals PDF each year.
- ** On-line access to all previous issues of American Woodturner and FUNdamentals.
- ** On-line access to videos and many other learning resources.

[AAW Membership Join or Renew](#)

American Association of Woodturners
222 Landmark Center,
75 5th Street
W St. Paul, MN 55102

Phone: (651) 484-9094 direct or toll free US (877) 595-9094

Email: memberservices@woodturner.org

Website: <https://www.woodturner.org/>

**“All you need to pursue a woodturning hobby
is a basic lathe, a few tools, and grinder.”**

Seen on another group's web site. Thought it was hysterical (and true), and I've decided that woodturners can put fishermen to shame when it comes to embellishing the truth. I'm often asked how I got into woodturning, and why my garage is so full of tools there's no room for my spouse's car beside my 4x4 pickup.

Well, you're gonna need a chainsaw to take advantage of all that free wood from downed trees so you can to shape them and get the blanks to fit on the lathe.

And a big 17" bandsaw is nice accessory tool for that too. I had a 14 inch with a 105" blade. It was too small.

Then you'll need special blades for your bandsaw because the ones best for green wood are toast for regular woodworking. PS. Carbide blades are a must!

And a few turning tools, at least two of each with their special grinds, and you'll need some negative rake and deep hollowing tools too

And a variety of finishes.

And a pressure pot.

And a burning wire or two or three, plus three different texturing tools. And a better compressor than the one gallon one you already own for the pressure pot.

And some resin and super glues.

And you're gonna want a brand for signing your work.

And a chuck. Or two. Or three. Or ?

Accessories for each chuck.

Or maybe a second dedicated faceplate and jam chucks.

Vacuum chucking is a super way of holding work to finish turning bowl bottoms.

Sandpaper. (LOTS)

And specialized sanding tools.

More turning tools.

A Japanese or flush cut saw. Just two?

Glue and fillers.

You're gonna want a bigger lathe.

And it's gonna need a 220 volt or even a three phase circuit..

SAE Metric and Number drills and good set of Forstner bits with extensions.

A drill press or at least a very good hand drill.:

And a center finding jig.

You'll need a sturdy bench or stand to mount your lathe on.

Oh yeah, don't forget a turning smock and some personal safety equipment to save your eyes, ears, and lungs.

Do we get kickbacks for luring newbies into this hobby? I haven't got mine yet.

Oh yeah, get some emulsified wax solution to keep your harvested green wood logs from cracking

A dust extraction system too. (a 6" trunk line and 4" drops to each sawdust maker).

Don't forget, you'll need a heated and air conditioned 24' x40' shop with a dedicated climate-controlled area for storing prepared wood and drying your partially turned green-wood projects. You'll also need a separate building to for the dust collector too. It's too noisy to have it in the shop!

I didn't believe how true old turner's sage advice turned out to be; **“Buy the best lathe you can afford, it will be the cheapest part of what you'll need.”**

Just when you have all the above and you think you're done, you'll find you need a bigger lathe and new tools because your old ones just aren't big enough!

!!!!HAPPYTURNING!!!!

Author Unknown