

Honey Dipper

Design: Dan England
 Drawn by: Tom Whalley

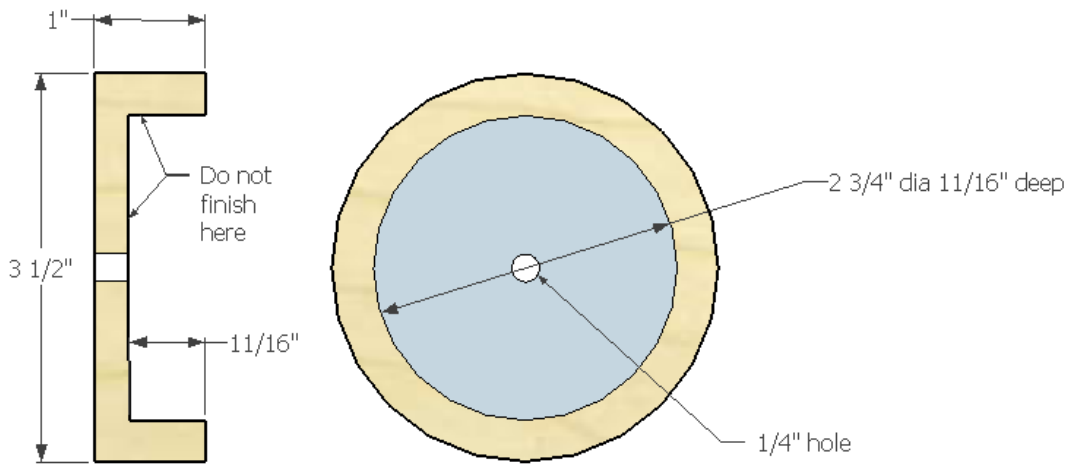

Lay out lids as shown and drill 2 3/4" dia 11/16" deep
 Drill 1/4" center hole.
 Rough out on the band saw.

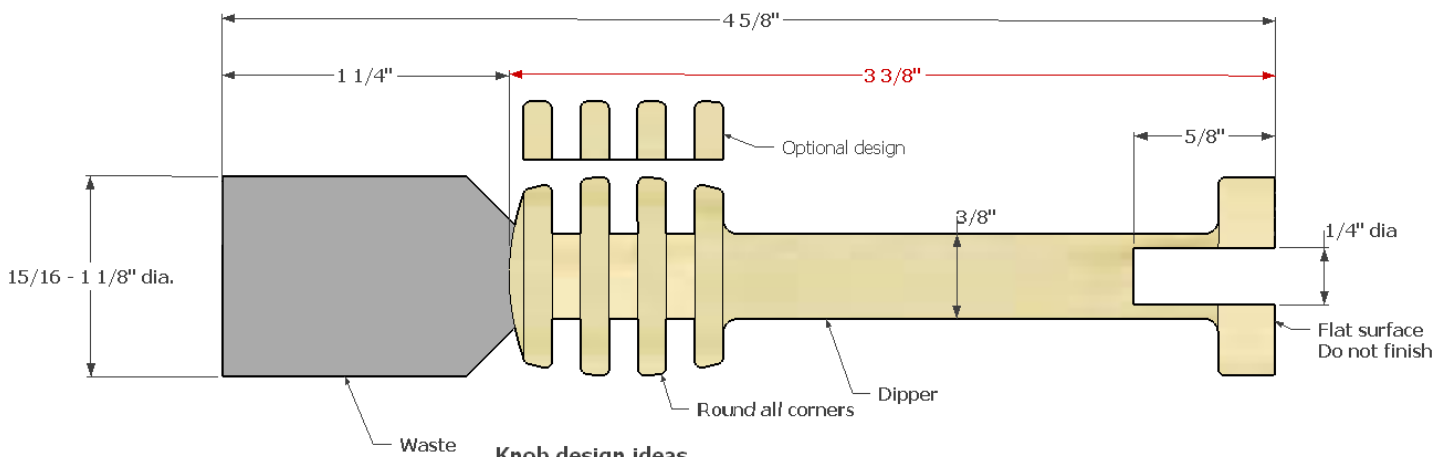
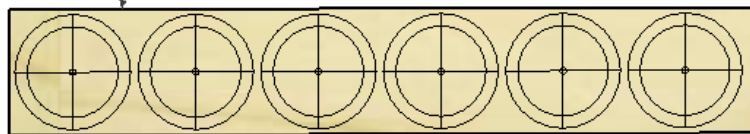

Knob design ideas

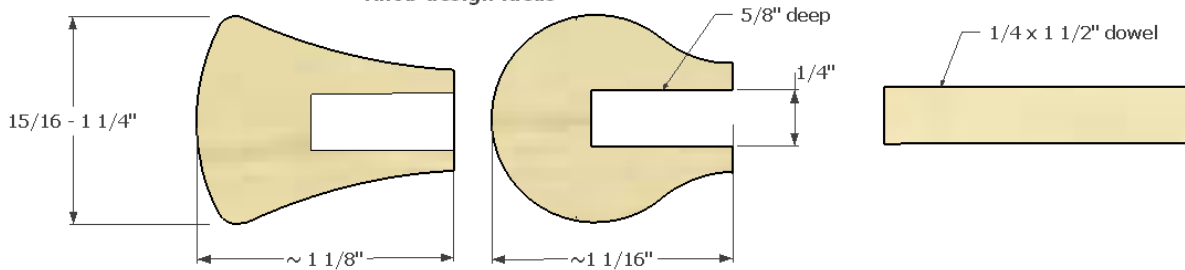

Honey Dipper Instructions

The Knob- Material:– 5/4 x 1-1/2” long – Hardwood. Do not use pine.

1. Mount the block on the lathe and drill a 1/4” hole 5/8” deep.
2. Turn the knob to any profile you choose. Remember, it is just a knob. Have fun with it They do NOT have to all be the same.
3. Part off and sand the top so that no parting marks are visible.

The Dipper - Material:– 5/4 hard maple or cherry

1. Turn the dipper as shown above.
2. **IMPORTANT** – the 3 3/8” dimension shown in red is also critical. If it is longer, the lid assembly will be too tall for the glass jar. Notice where the measurement starts and ends.
3. Sand smooth and finish with butcher block finish (but not the flat surface as shown above)
4. The 1 1/2” dowel may need to be sanded to fit into the dipper. It should not be a tight fit because it may split the dipper or the knob later. Glue the dowel into the end of the dipper. Remove glue squeeze out. Do not finish the surface of the dowel.
5. Finish only where shown with butcher block finish.

The Wood Lid – Material: 5/4 Hardwood - Same as knob. Do not use pine.

1. Drill 2 3/8” dia. x 11/16” deep recess.
2. Turn the lid to a 3 1/2” diameter.
3. Drill a 1/4” hole in the center of each lid.
4. Sand and finish the outside and bottom rim only. Do not finish the inside that was drilled out.
5. Using Gorilla 2-part epoxy, glue the jar ring to the lid and let dry. Do not over apply adhesive resulting in squeeze out around the outside of the jar ring. Do not get adhesive on the threaded rings inside the jar ring.
6. Glue the metal lid into the ring using Gorilla 2-part epoxy, clamp and let dry.
7. Carefully drill a 1/4” hole through the hole in the wood lid through the metal lid while holding a block under the lid assembly for support and to prevent the metal from bending.
8. Dry-fit the dipper through the hole in the lid and insert the knob. Make sure the knob fits tight against the lid. If the glue dowel is too long, trim it back before gluing the knob to it.
9. If all is well, glue the dipper to the lid using Gorilla 2-part epoxy and let it dry.
10. Glue the knob tightly to the lid using Titebond glue.
11. Finish the lid assembly
12. Buff the lid assembly.